

Understanding Online Learning

Overview

- Advantages and disadvantages of online learning
- Elements of Online Learning
- What Works, What Doesn't
- The Future of Online Learning

Advantages and Disadvantages

Advantages

- For your students: ease of access, cost, variable schedule
- For you: creation of re-usable content, distribution of resources (no photocopying!), clarification of subject
- More?

Advantages and Disadvantages (2)

- Disadvantages
- For students: cost or inconvenience of access, technology woes, lack of direct contact
- For you: need to prepare material ahead of time, technology woes, increased workload handling email, etc
- More?

Elements of Online Learning

- The Assiniboine Model (1997)

<http://www.atl.ualberta.ca/downes/naweb/am.htm>

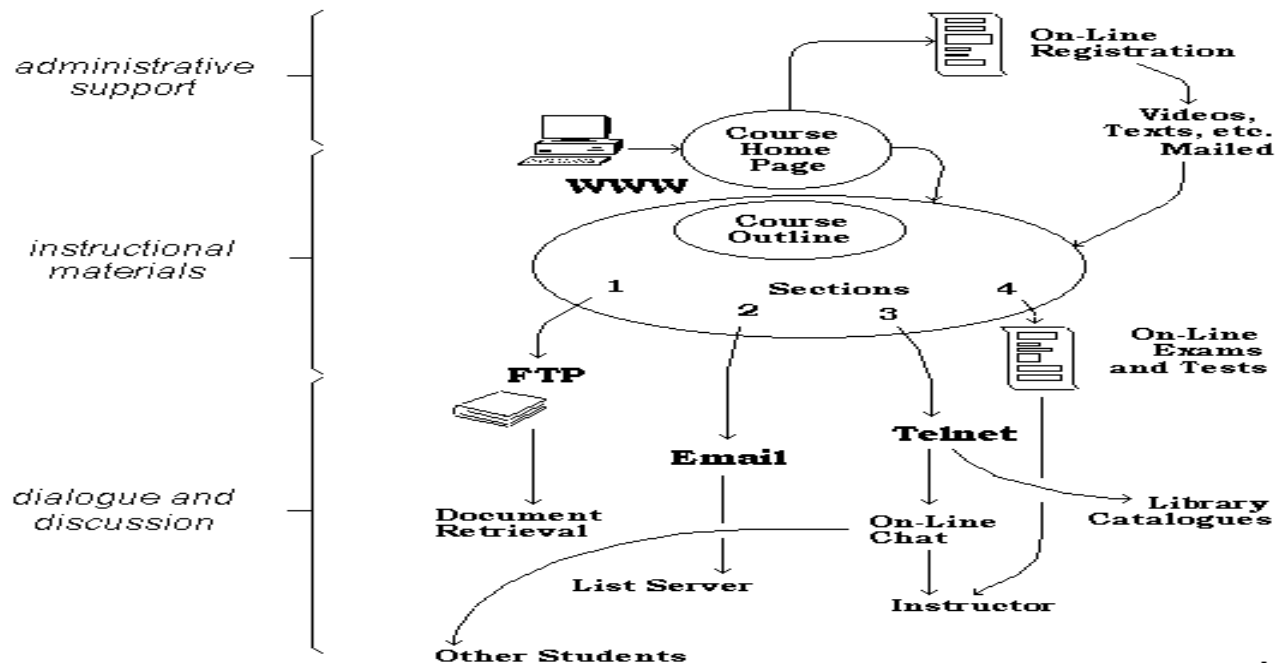

Elements of Online Learning (2)

- Course Structure

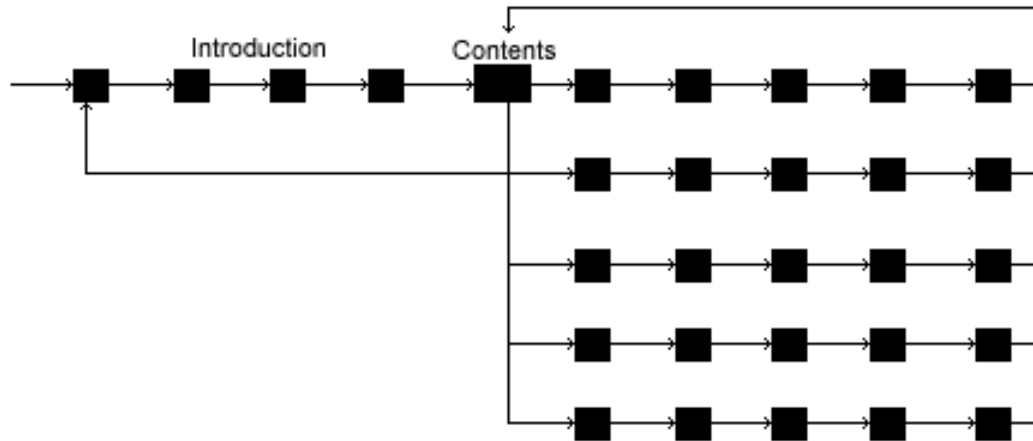

Elements of Online Learning (3)

- Module Structure

The IDEAS Model:

Information

Description

Exercises

Assignment

Summary

Elements of Online Learning (4)

- Modules and Static Resources

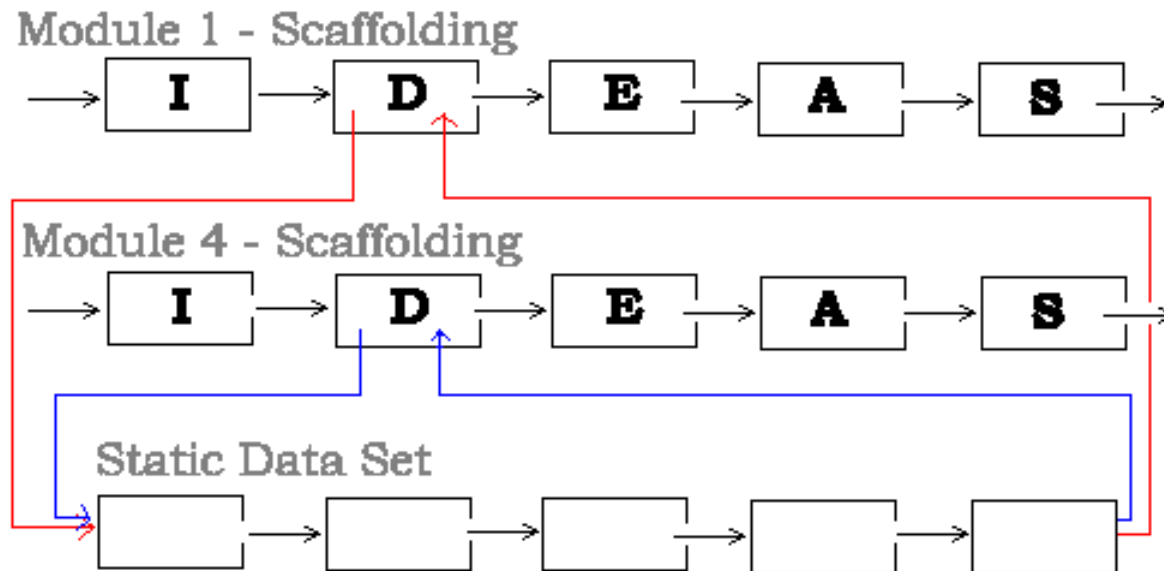

Elements of Online Learning (5)

- Overview

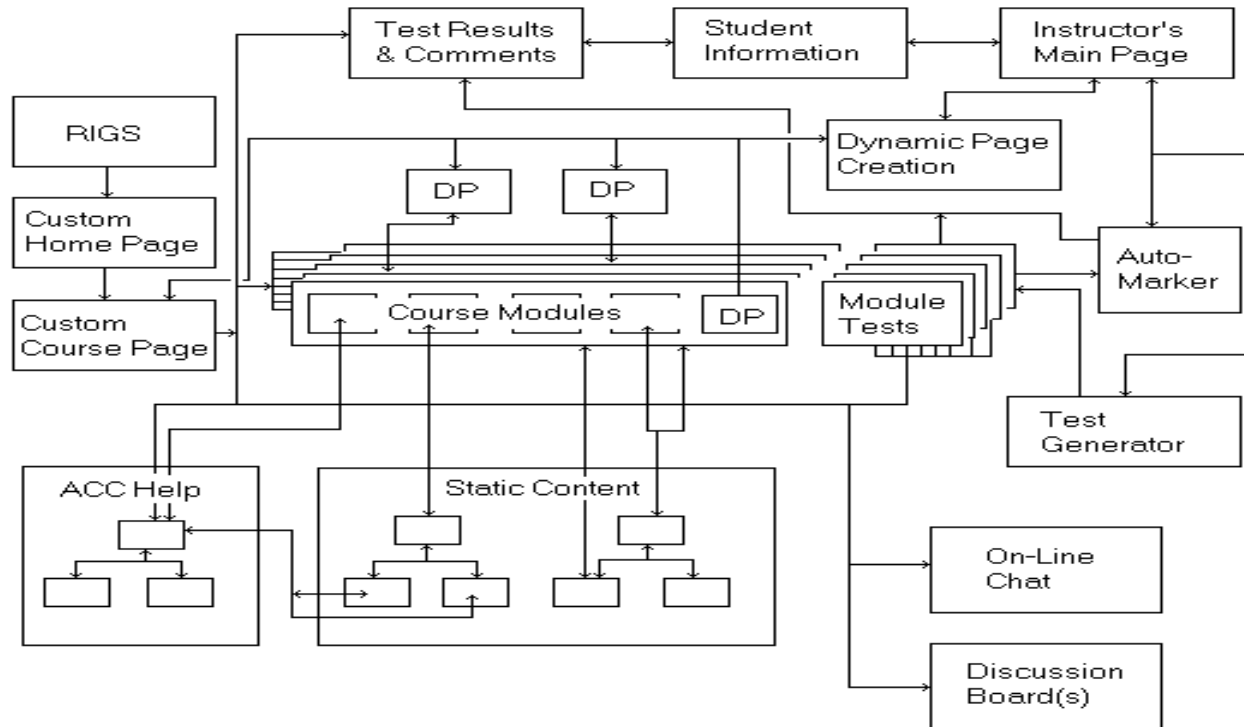

What Works, What Doesn't

- Being a cornucopia of online learning experiences....



What Works... (1)

- Intro to Literature

<http://web.cerritos.edu/jaeger/en2spsyl.htm>

English 102 - Advanced Freshman Comp/Intro to Literature	
Spring 2001	
Dr George Jaeger	
01/31/2000	
	
SECTION 1	How to reach the teacher, email, homework assignments and more.
SECTION 2	Course Purpose, Prerequisite, textbook, grading scale, late work.
SECTION 3	Writing Assignments: Types of Essays and Essay due dates
SECTION 4	How to fill in your name on your Essays and other Homework

What Works... (2)

- Small Business Management

<http://clconline.clc.cc.il.us/bus219>

College of Lake County

Small Business Management (BUS 219-800)



Entrance

What Works... (3)

- Shakespeare and Performance Criticism

<http://www.cyberschool.k12.or.us/~ulen/shakespeare1/welcome.html>

Shakespeare

ALL THE WORLDS A STAGE
Shakespeare & Performance Criticism

- Welcome
- Description
- Teacher
- Lessons
- Discussion
- Mailing List
- Projects
- Calendar
- Help
- 2nd Semester
- Registration
- CyberSchool

Shakespeare. Why are the works of a man who has been dead for almost 400 years still so popular? Why must students from around the world be *forced* to study his plays? Many English teachers will tell you that it is because Shakespeare is "the greatest writer in the English language." As true as that statement may be, it isn't always enough to hold the interest of students. So, students continue to wonder...why Shakespeare?

To begin to answer this question, we must look to the stage. Shakespeare is the most frequently produced playwright in the world. Why? Is it because generations of theatre artists and movie makers fondly remember their English teachers' words of wisdom about "the greatest writer in the English language"? Is it because Shakespeare's plays are public domain and can be produced without paying royalties? Could this be why there are dozens of full-time professional Shakespeare companies and summer Shakespeare festivals in the United States alone? Shakespeare remains popular in non-English speaking countries as well. On the internet, Shakespeare translations can be found in German, Chinese, and Klingon! Whatever the reason, whatever the language, Shakespeare is alive and

What Works... (4)

- Computer Supported Collaborative Learning

http://webct.cc.utexas.edu:8900/SCRIPT/EDC385G_F00/scripts/serve_home williams / joanne



The screenshot shows a newsletter header for CSCL Technology Inc. with the text "computer supported collaborative learning" and a logo of overlapping circles. Below the header, the newsletter title "CSCL Technology Inc. Newsletter" is displayed with a date of "December 1, 2000". A yellow box highlights the "Latest News" section, which includes the text "Webcast Monday, December 4, from 5:30 - 7:30 pm" and "Oncampus Students Do Course Evaluations After Webcast". Below this, there is a link for "Webcast Monday, December 4 - Details" and an "Overview" section starting with "In the first hour: White Paper Report - we thought of giving the group that did each".

computer supported collaborative learning

CSCL Technology Inc. 

CSCL Technology Inc.  Newsletter

December 1, 2000

Latest News: Webcast Monday, December 4, from 5:30 - 7:30 pm
Oncampus Students Do Course Evaluations After Webcast

[Webcast Monday, December 4 - Details](#)

Overview: In the first hour: White Paper Report - we thought of giving the group that did each

What Works... (5)

- Introduction to Using Online Discussion
<http://learnnow.nait.ab.ca:8500/webct/public/home.pl> tci100s9 /
tci100s9

The screenshot shows a web browser window displaying the NAIT web interface. At the top, there is a navigation bar with the NAIT logo and links for MYWEBCT, RESUME COURSE, COURSE MAP, and HELP. Below this, the course title "TCI100: Introduction to Using Online Discussion" and "Home" are displayed. A large banner reads "Welcome to NAIT on the Web". The main content area features the text "Welcome to TCI100" and "Introduction to Using Online Discussions", followed by instructions: "Use the links to the left in Course Menu and at the top in Action Menu to navigate through this module." At the bottom, it states "This module is the property of The Northern Alberta Institute of Technology." On the left side, there is a "Course Menu" with a scrollable list of links: Hide Navigation, Expand Content, Homepage, Course Contents, Communications, Email Instructor, Email Helpdesk, Link to Outlook, Discussions, Chat, Whiteboard, Student Evaluation, Quizzes, My Grades, My Progress, Assignments, Course Tools, Link to Library, Search Content, and Glossary.

What Works... (6)

- A Hole in the Wall

<http://www.finalcopygroup.com/wallrepair/>



The Future of Online Learning

Three Components:

- Knowledge management
- Learning communities
- Learning Objects

The Future... (2)

Communities

- Jurist <http://jurist.law.pitt.edu/>
- MuniMall <http://www.munimall.net>

And More...

- Stephen's Web
- <http://www.atl.ualberta.ca/downes>
- (soon to be <http://www.downes.ca>)